

Standortübersicht



Farbzuteilung Grundrisse

Kindergarten und Schule:

- Kindergartenraum
- Klassenzimmer / Gruppenraum
- Gestalten / Fachunterricht / WAH / Therapie
- Aula / Musikraum / Mehrzweckraum
- Lehrer / Schulleitung / Schulsozialarbeit (SSA)
- Bibliothek / Mediothek
- Material

Sport, Tagesschule und Externe:

- Turnhalle
- Tagesschule
- Externe / Zivilschutz

Nebennutzungen und Verkehrsflächen:

- Hauswart / Technik / Privat
- Erschliessung / Garderobe
- WC / Dusche



Gemeinde Ostermundigen

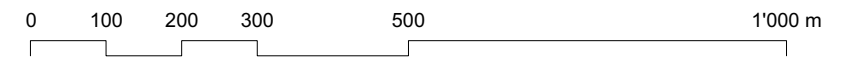

Schulraumplanung

Übersicht Standorte / Farbzuteilung Grundrisse

1:10'000

Plan-Nr.	0.0.1	Dateiname	Katasterplan
Grösse	A3	Status	Entwurf
Erstellung	10.12.2018	Grundlage	Amtliche Vermessung vereinfacht
Revision	25.01.2019		© Amt für Geoinformation des Kantons Bern
Projektverfasserin	IC Infraconsult AG		

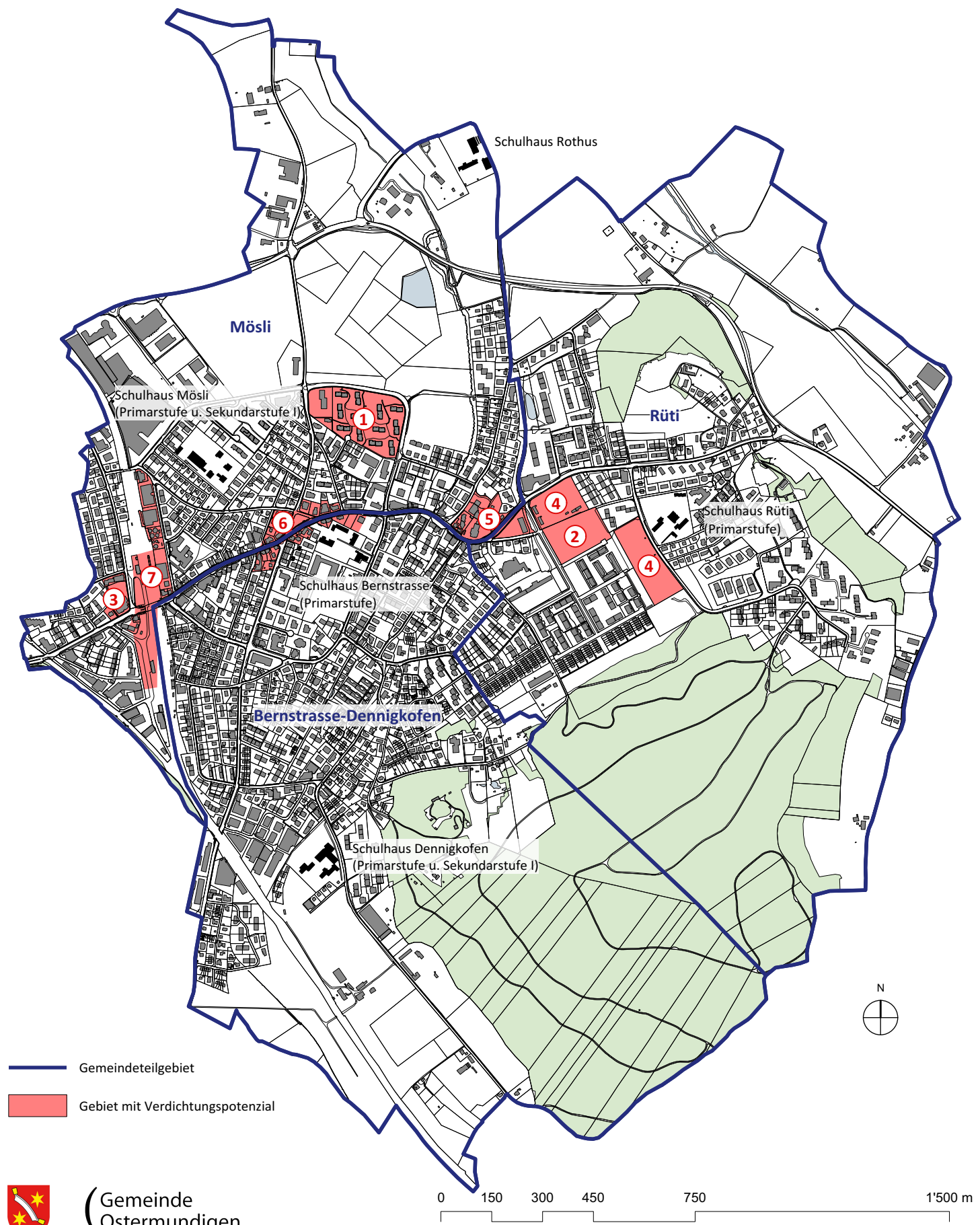

Gemeinde Ostermundigen

Schulraumplanung

Einteilung Gemeindeteilgebiete

1:15'000

Plan-Nr.	0.0.2	Dateiname	Gemeindeteilgebiete
Grösse	A3	Status	Entwurf
Erstellung	10.12.2018		
Revision	25.01.2019		
Projektverfasserin	IC Infraconsult AG		

1. Obergeschoss

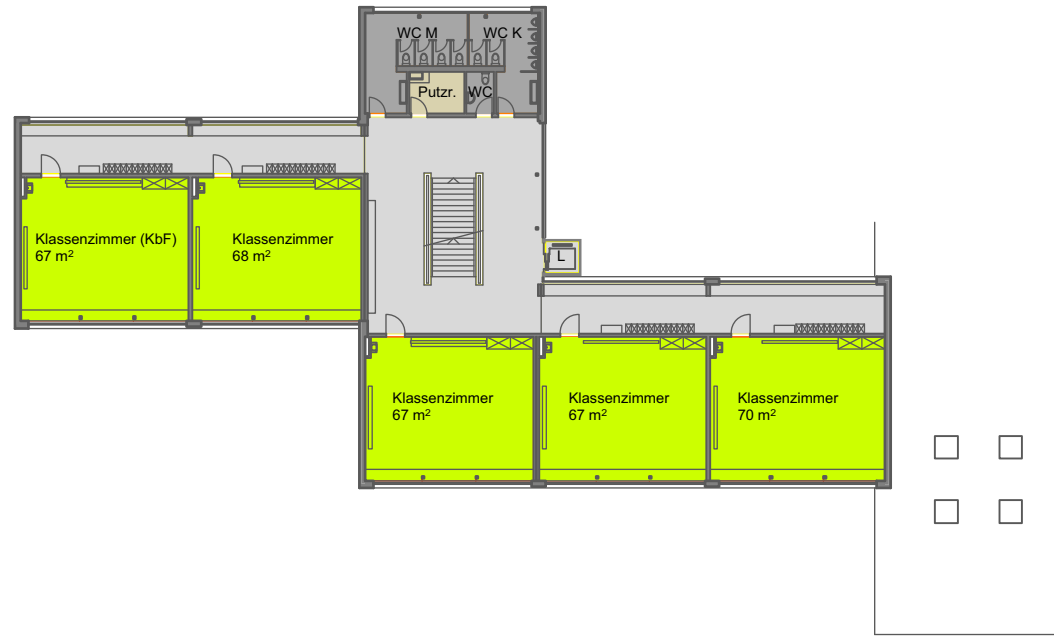

2. Obergeschoss

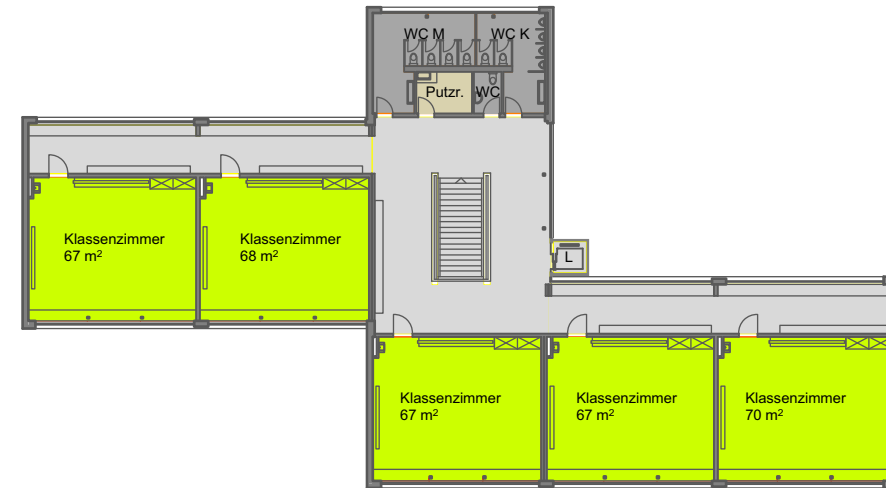

Erdgeschoss

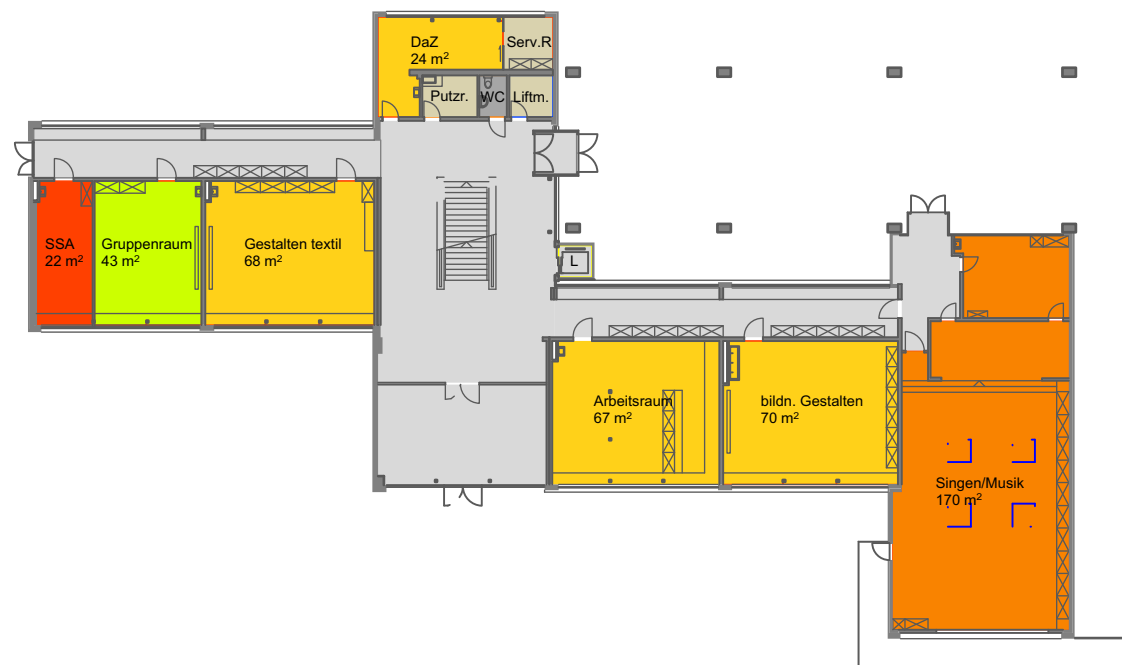

Gemeinde Ostermundigen

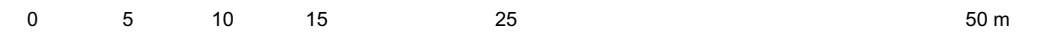

Schulraumplanung

Schulanlage Dennigkofen; Bestand

Grundrisse Trakt 1

1:400

Plan-Nr.	0.1.1	Dateiname	SH_Dennigkofen
Grösse	A3	Status	Entwurf
Erstellung	10.12.2018		
Revision	25.01.2019		
Projektverfasserin	IC Infraconsult AG		

4. Obergeschoss

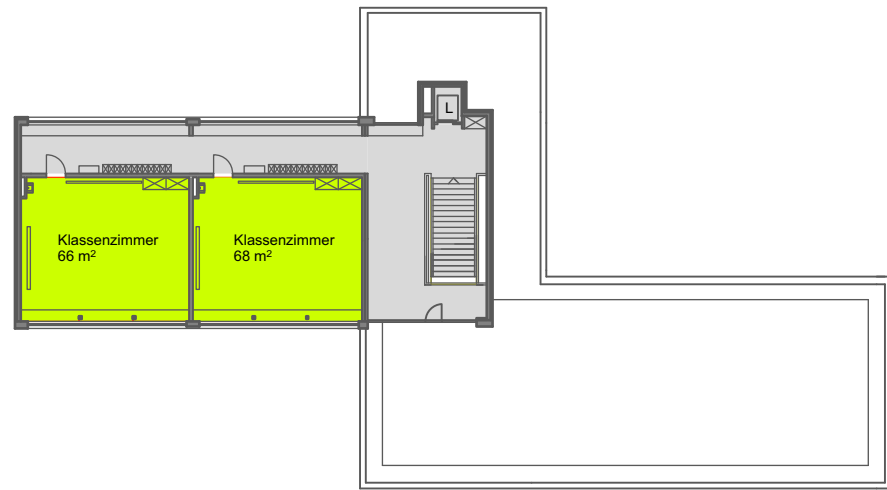

3. Obergeschoss

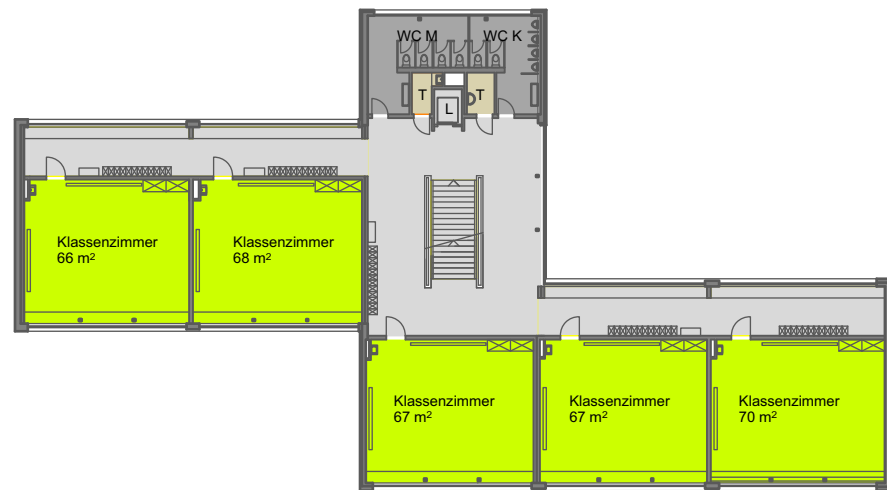

2. Obergeschoss



1. Obergeschoss



Erdgeschoss

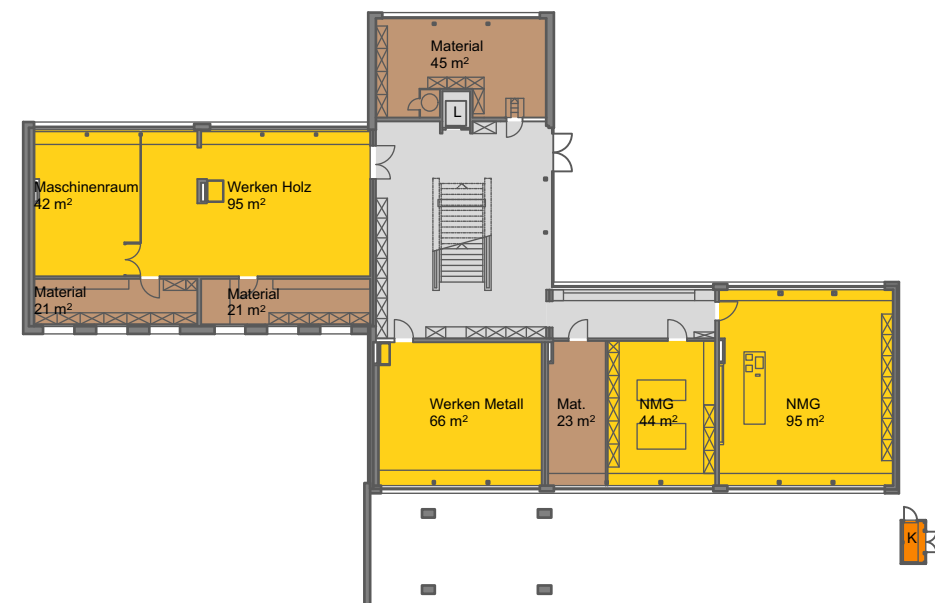

Gemeinde Ostermundigen

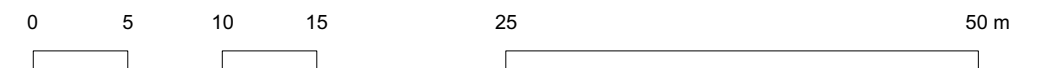

Schulraumplanung

Schulanlage Dennigkofen; Bestand

Grundrisse Trakt 2

1:400

Plan-Nr.	0.1.2	Dateiname	SH_Dennigkofen
Grösse	A3	Status	Entwurf
Erstellung	10.12.2018		
Revision	25.01.2019		
Projektverfasserin	IC Infraconsult AG		

2. Untergeschoss



1. Untergeschoss



3. Untergeschoss

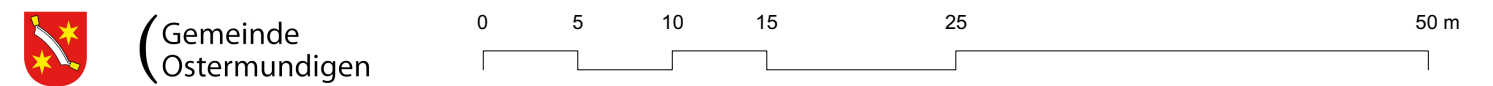
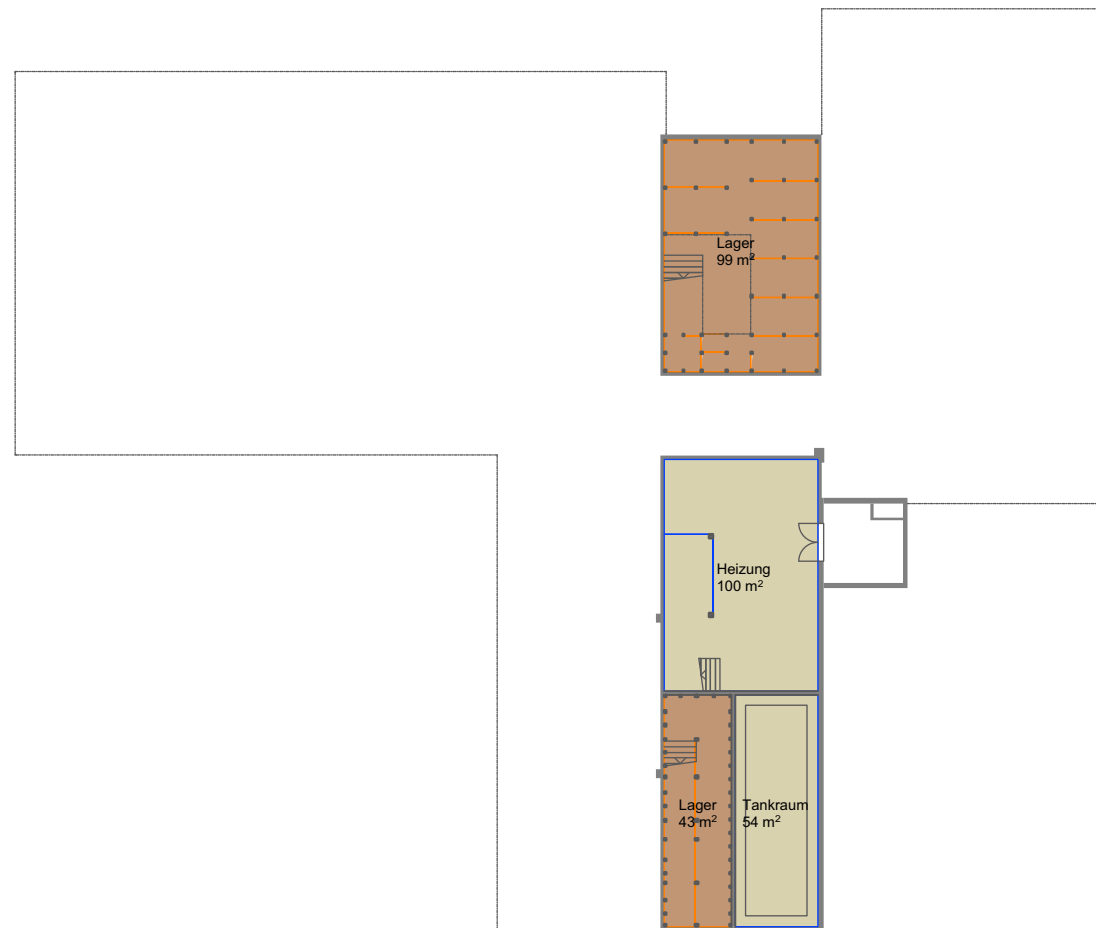

Schulraumplanung

Schulanlage Dennigkofen; Bestand

Grundrisse UG1/UG2/UG3 Trakt 3

1:400

Plan-Nr.	0.1.3	Dateiname	SH_Dennigkofen
Grösse	A3	Status	Entwurf
Erstellung	10.12.2018		
Revision	25.01.2019		
Projektverfasserin	IC Infraconsult AG		

Erdgeschoss



Obergeschoss

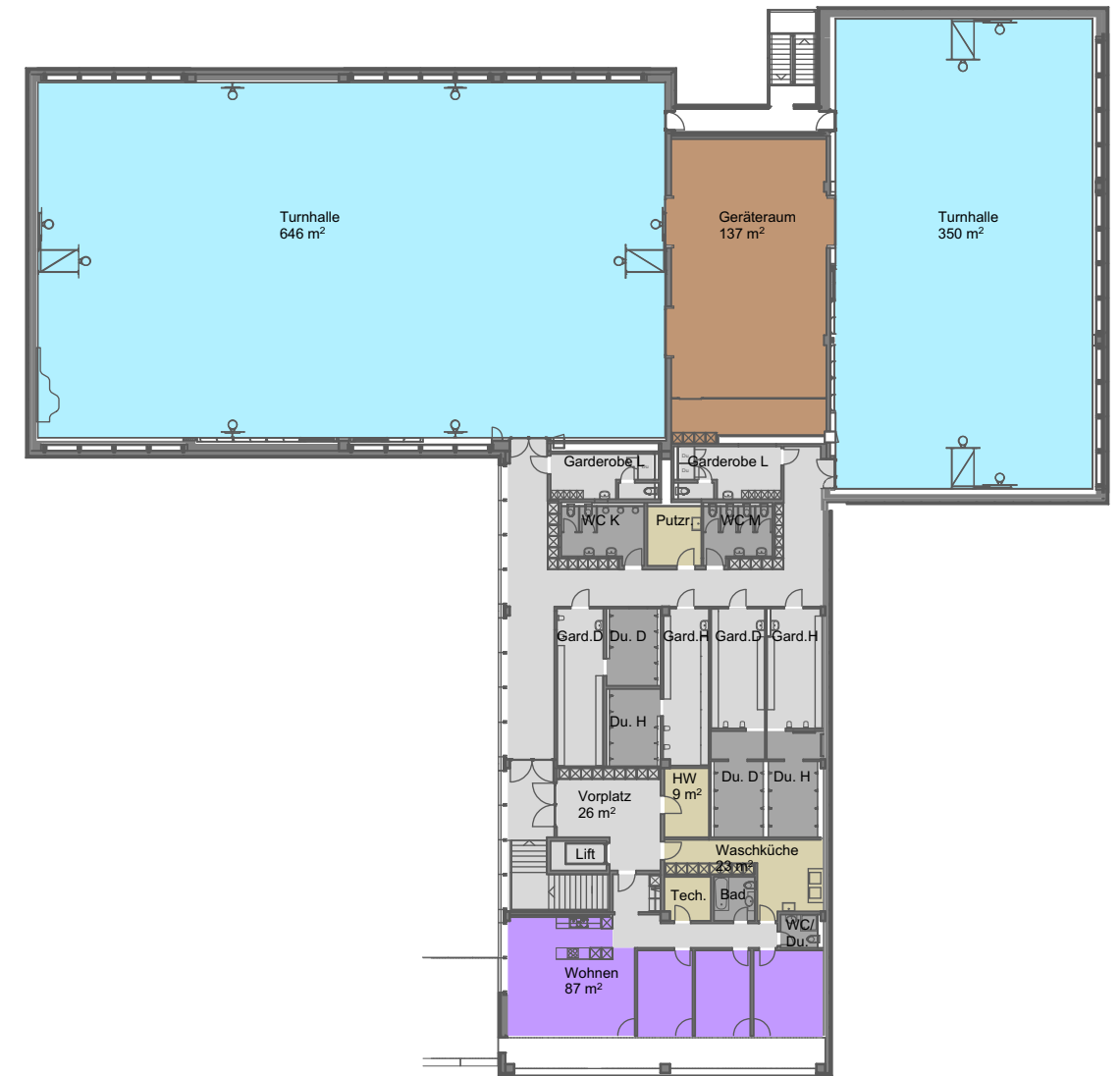

Gemeinde Ostermundigen

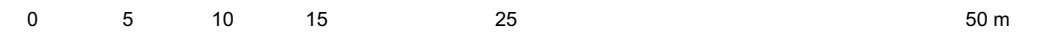

Schulraumplanung

Schulanlage Dennigkofen; Bestand

Grundrisse EG/OG Trakt 3

1:400

Plan-Nr.	0.1.4	Dateiname	SH_Dennigkofen
Grösse	A3	Status	Entwurf
Erstellung	10.12.2018		
Revision	25.01.2019		
Projektverfasserin	IC Infraconsult AG		

Mösli Pavillon 1

2. Obergeschoss

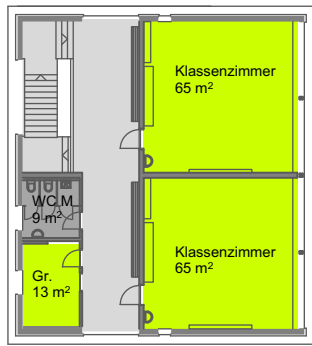

1. Obergeschoss

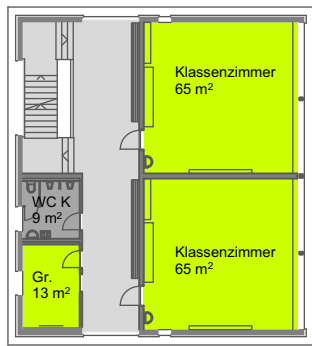

Erdgeschoss

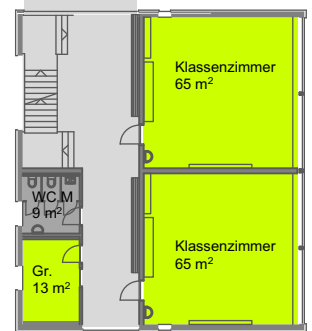

Untergeschoss

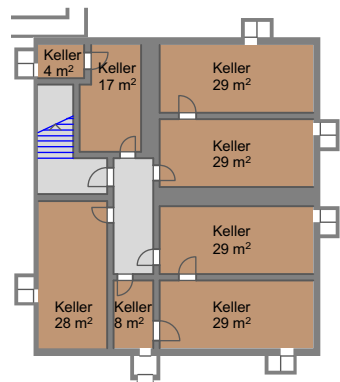

Mösli Pavillon 2

2. Obergeschoss

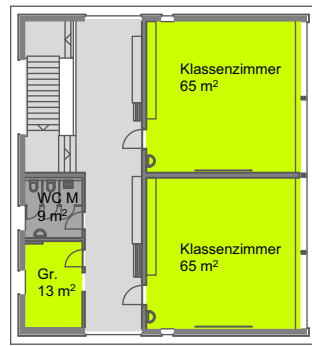

1. Obergeschoss

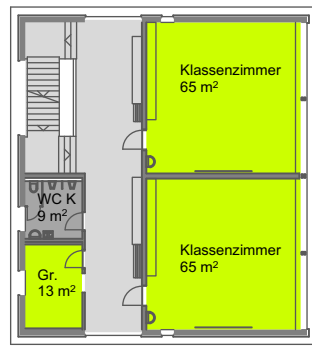

Erdgeschoss

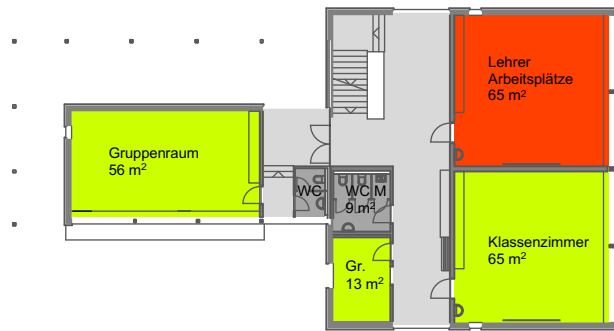

Untergeschoss

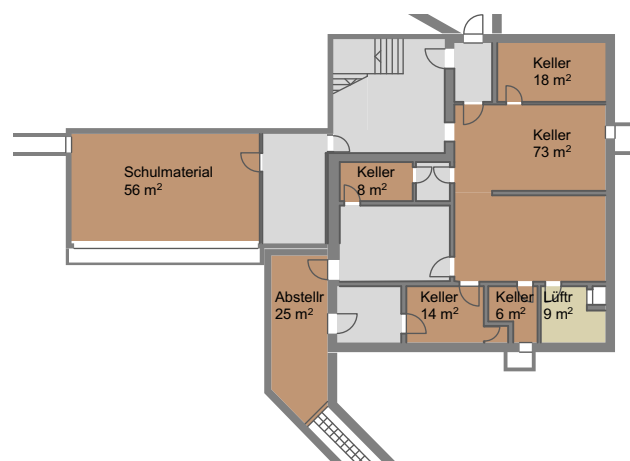

Mösli Spezialtrakt

Obergeschoss

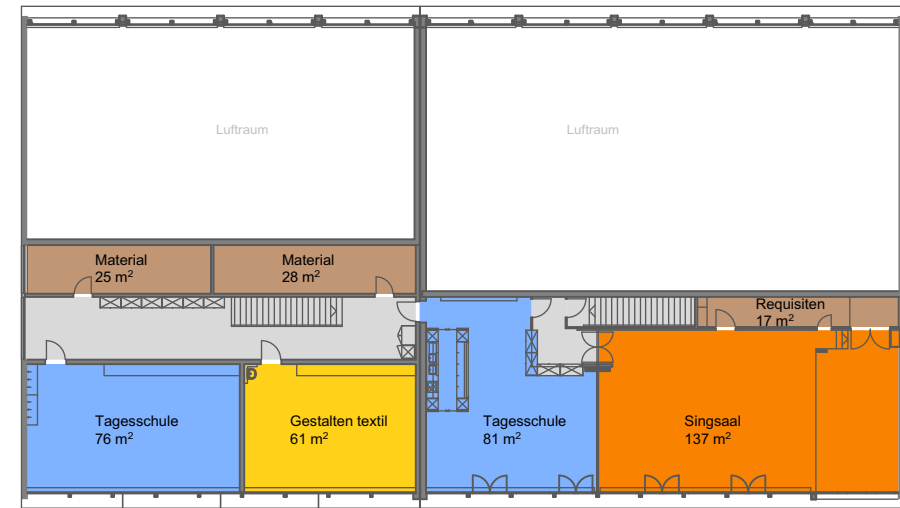

Erdgeschoss

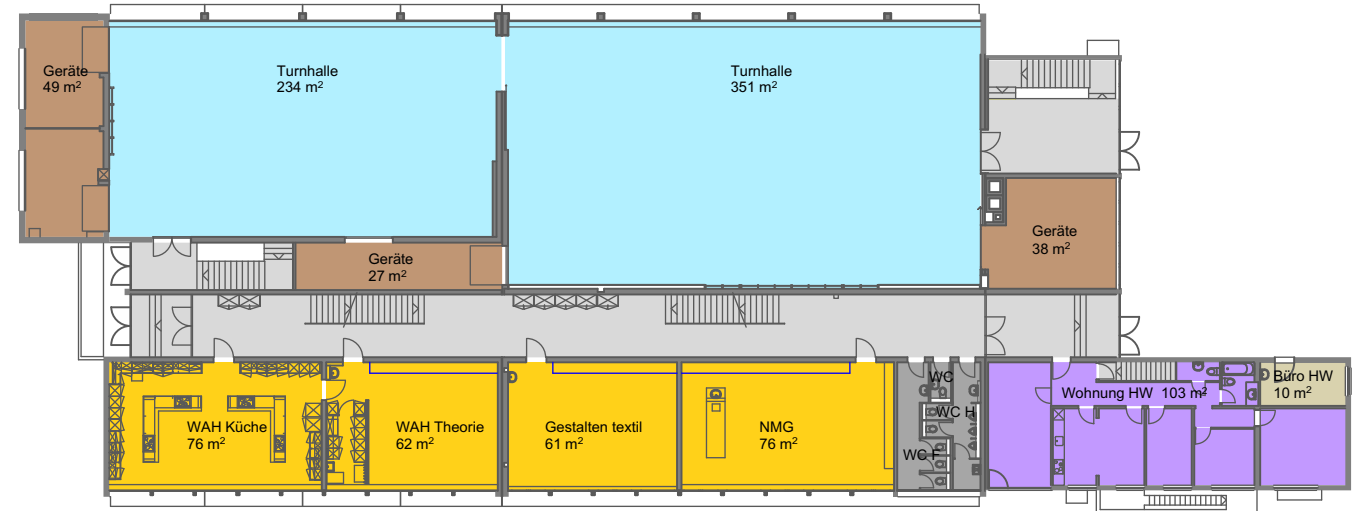

Gemeinde Ostermundigen

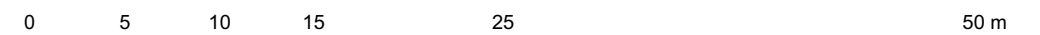

Schulraumplanung

Schulanlage Mösli; Bestand

Grundrisse Pavillon 1, Pavillon 2, Spezialtrakt

1:400

Plan-Nr.	0.2.1	Dateiname	SH_Mösli
Grösse	A3	Status	Entwurf
Erstellung	10.12.2018		
Revision	25.01.2019		
Projektverfasserin	IC Infraconsult AG		

Mösli Pavillon 3

2. Obergeschoss

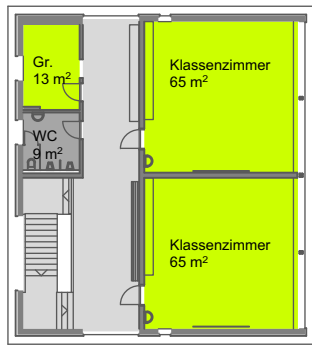

1. Obergeschoss

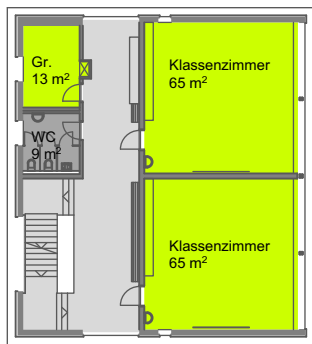

Erdgeschoss

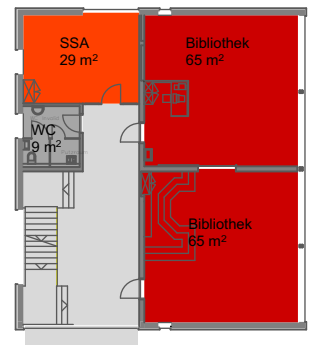

Untergeschoss

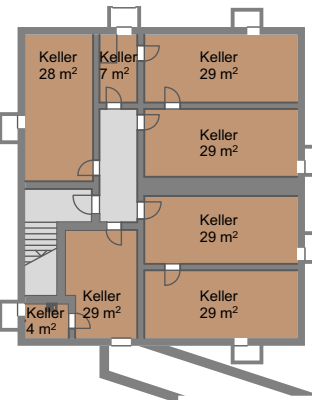

Mösli Pavillon 4

2. Obergeschoss

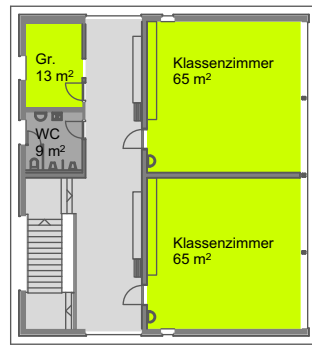

1. Obergeschoss

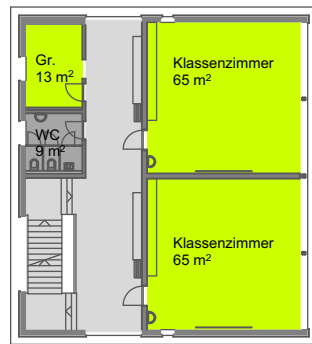

Erdgeschoss

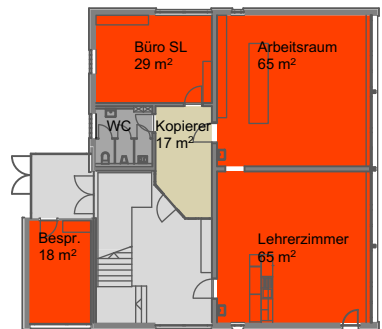

Untergeschoss

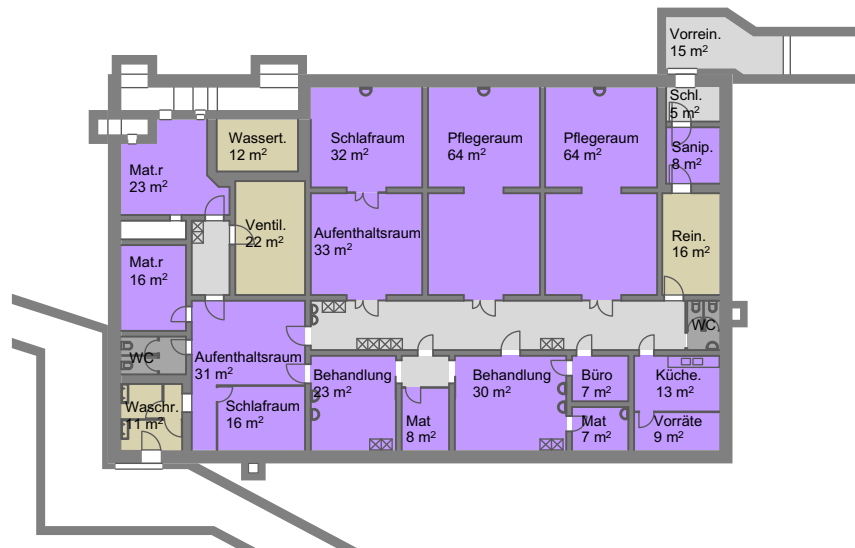

Mösli Spezialtrakt

Untergeschoss

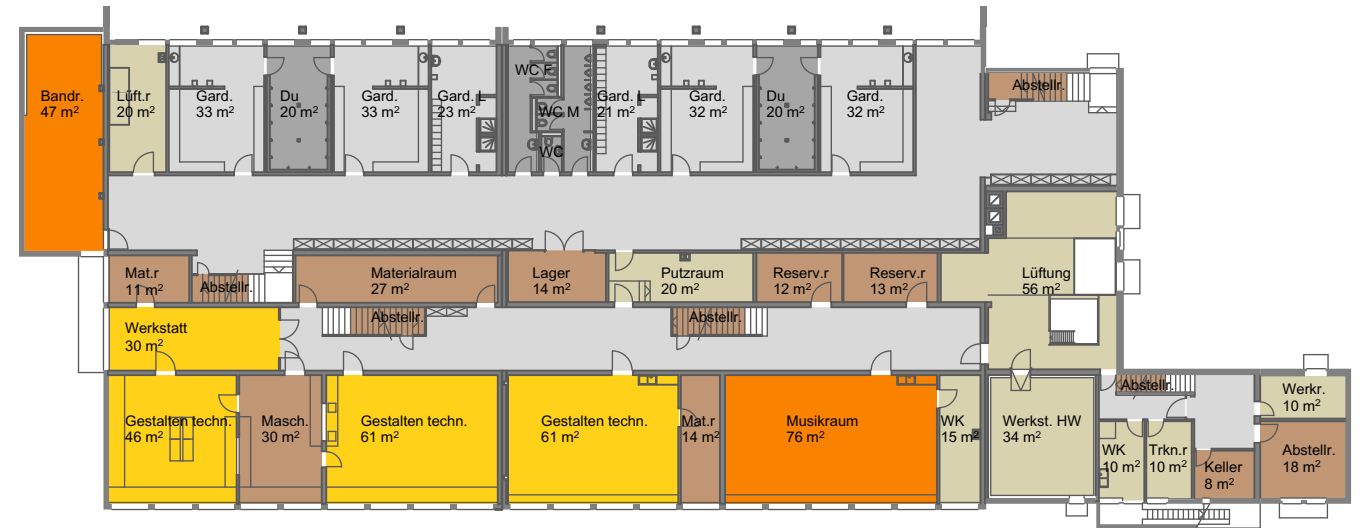

Mösli Tagesschule und Kindergarten

(Neubau projektiert)

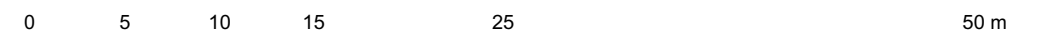

Schulraumplanung

Schulanlage Mösli; Bestand

Grundrisse Pavillon 3, Pavillon 4, Spezialtrakt

1:400

Plan-Nr.	0.2.2	Dateiname	SH_Mösli
Grösse	A3	Status	Entwurf
Erstellung	10.12.2018		
Revision	25.01.2019		
Projektverfasserin	IC Infraconsult AG		

1. Obergeschoss

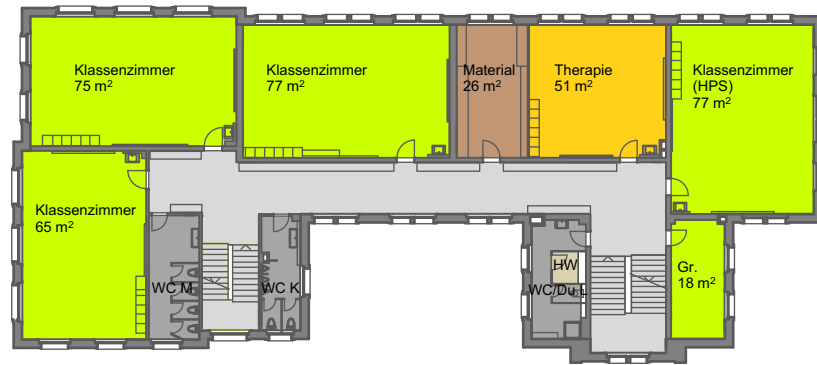

3. Obergeschoss

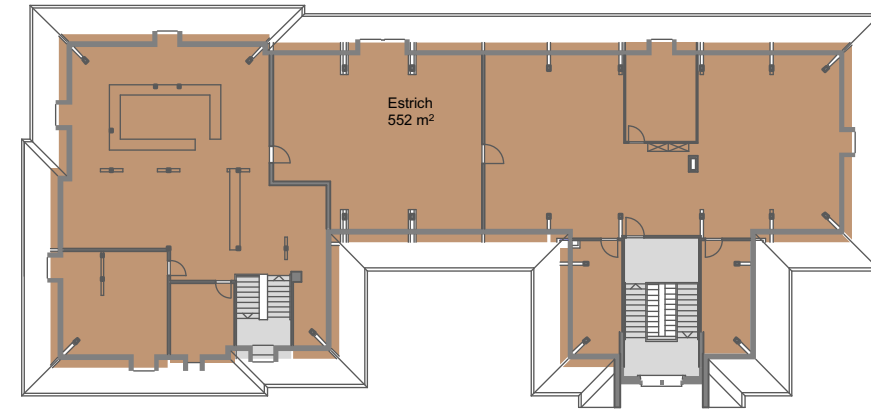

Erdgeschoss

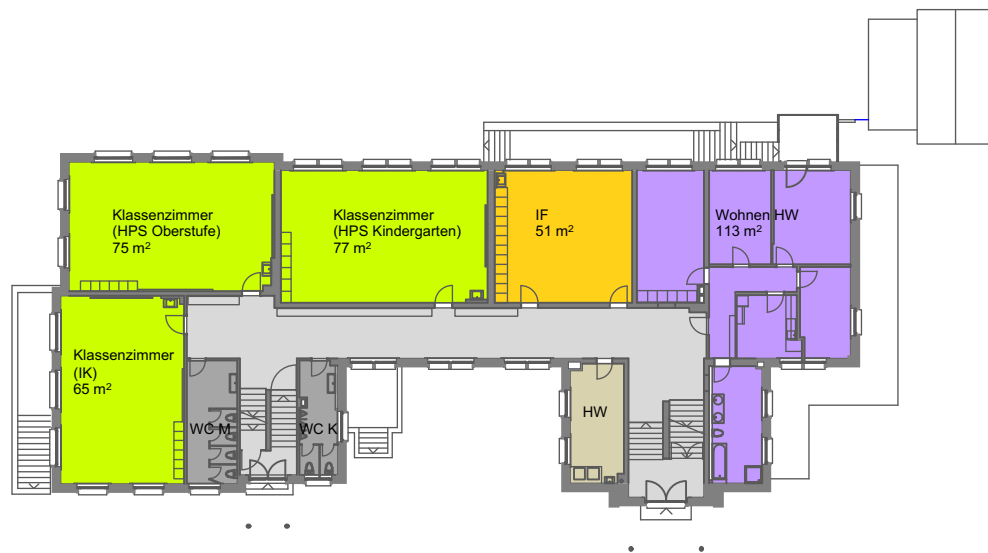

2. Obergeschoss

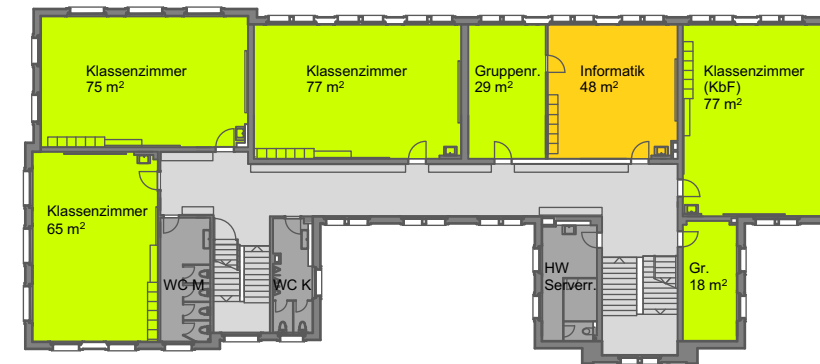

1. Untergeschoss

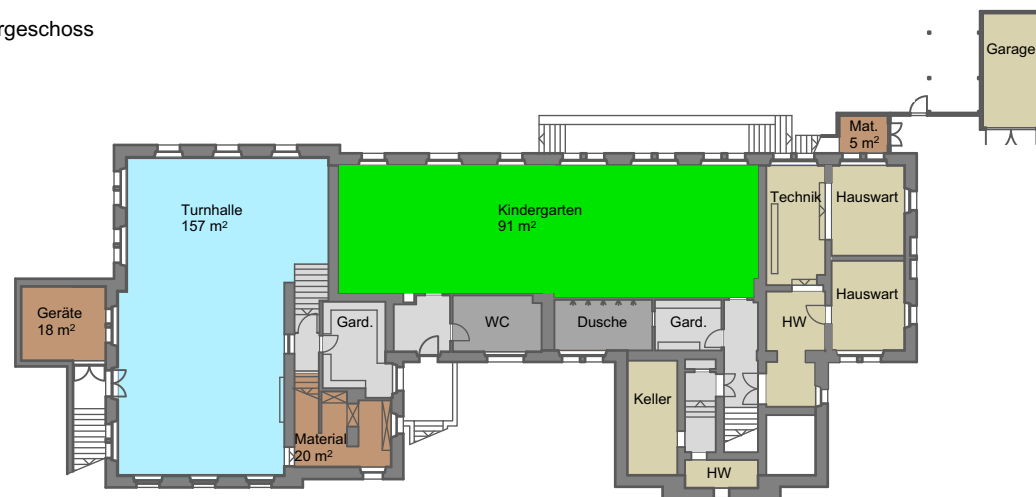

Gemeinde Ostermundigen

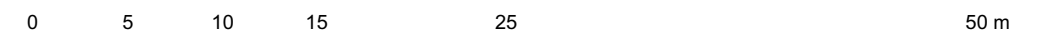

Schulraumplanung

Schulanlage Bernstrasse; Bestand

Grundrisse Schulhaus 1

1:400

Plan-Nr.	0.3.1	Dateiname	SH_Bernstrasse
Grösse	A3	Status	Entwurf
Erstellung	10.12.2018		
Revision	25.01.2019		
Projektverfasserin	IC Infraconsult AG		

1. Obergeschoss

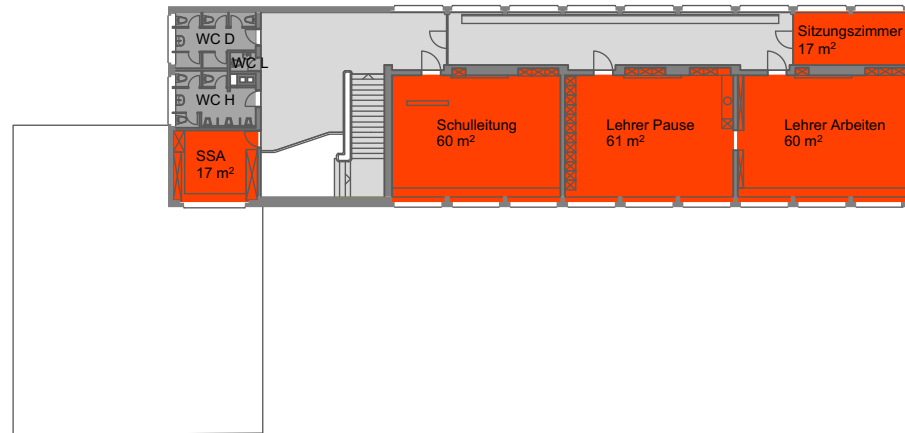

Erdgeschoss

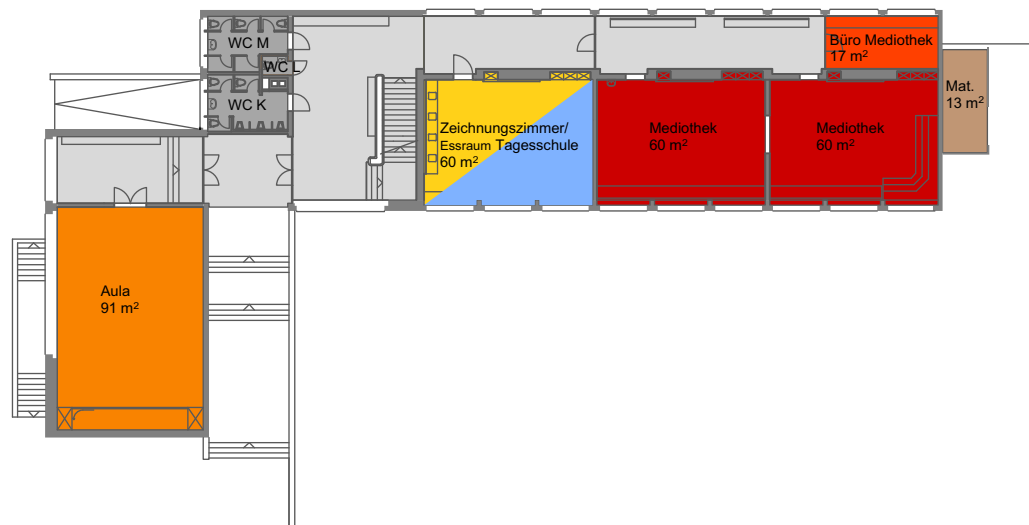

1. Untergeschoss

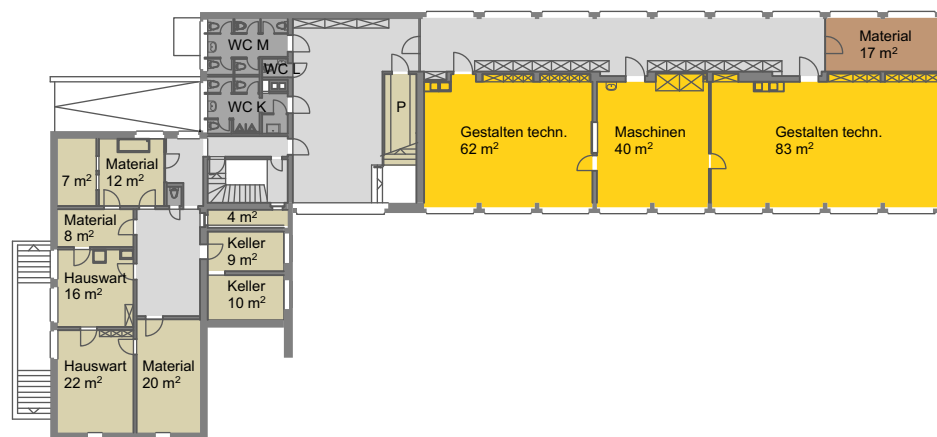

Untergeschoss

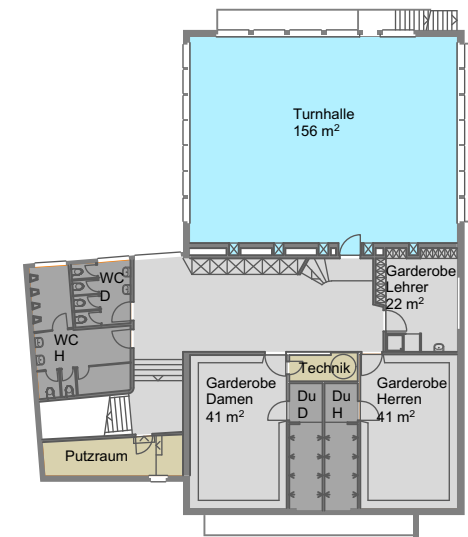

Erdgeschoss

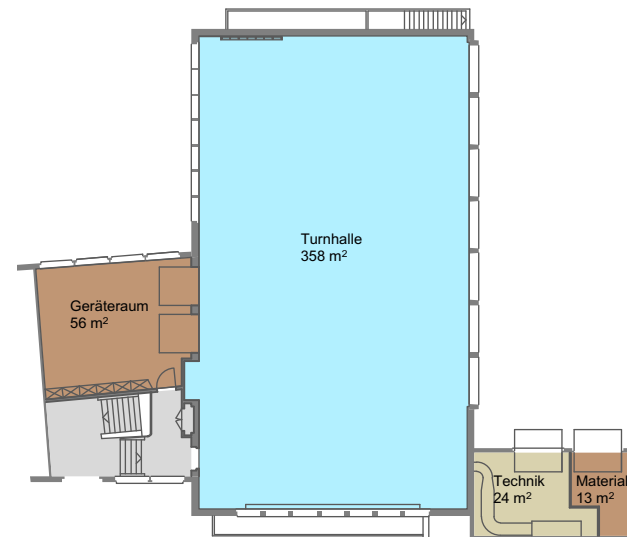

Gemeinde Ostermundigen

0 5 10 15 25 50 m

Schulraumplanung

Schulanlage Bernstrasse; Bestand

Grundrisse Schulhaus 2 und Turnhalle

1:400

Plan-Nr.	0.3.2	Dateiname	SH_Bernstrasse
Grösse	A3	Status	Entwurf
Erstellung	10.12.2018		
Revision	25.01.2019		
Projektverfasserin	IC Infraconsult AG		

1. Obergeschoss

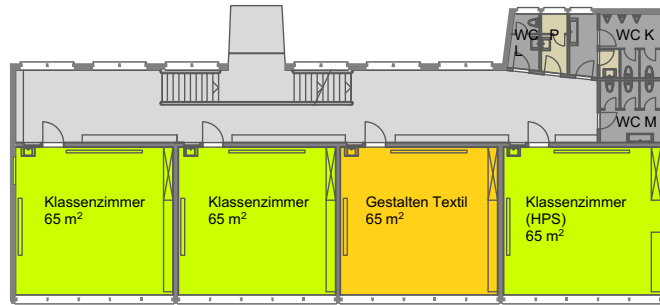

Erdgeschoss

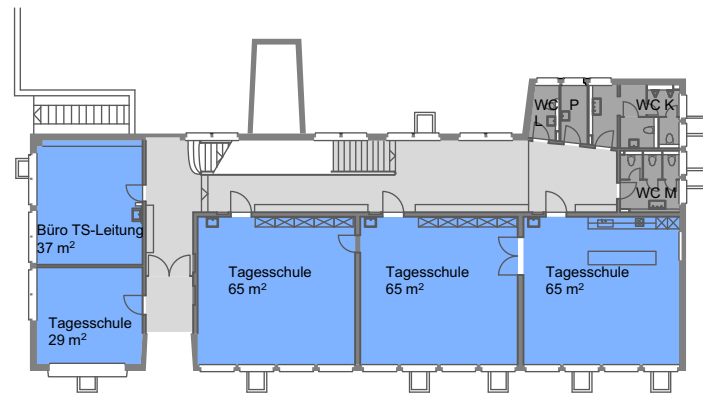

1. Untergeschoss

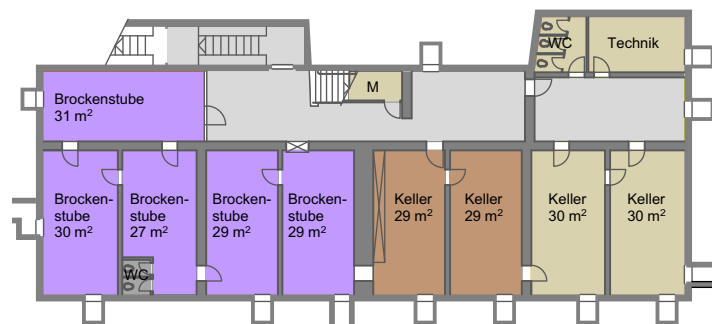

3. Obergeschoss

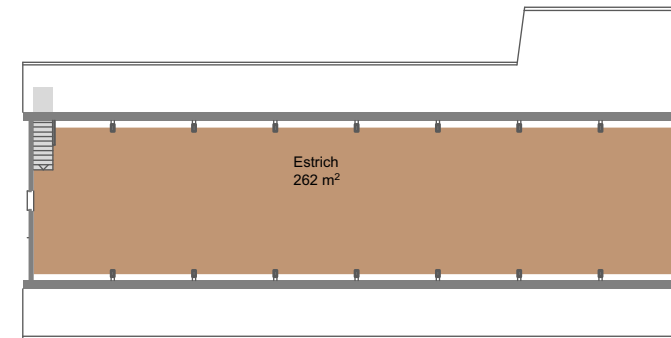

2. Obergeschoss

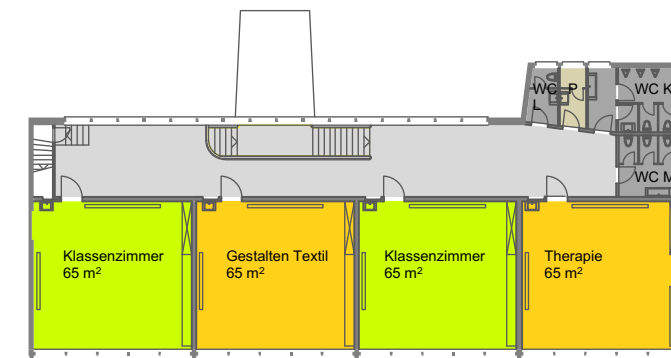

Gemeinde Ostermundigen

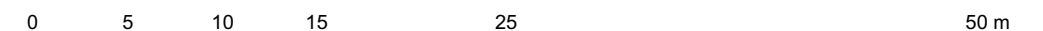

Schulraumplanung

Schulanlage Bernstrasse; Bestand

Grundrisse Schulhaus 3

1:400

Plan-Nr.	0.3.3	Dateiname	SH_Bernstrasse
Grösse	A3	Status	Entwurf
Erstellung	10.12.2018		
Revision	25.01.2019		
Projektverfasserin	IC Infraconsult AG		

1. Obergeschoss

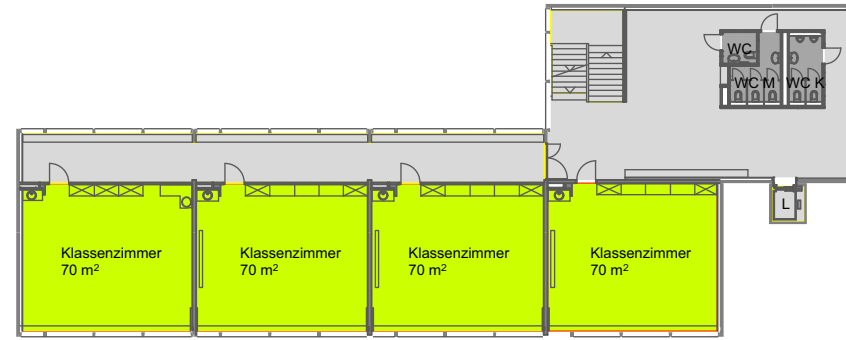

Erdgeschoss

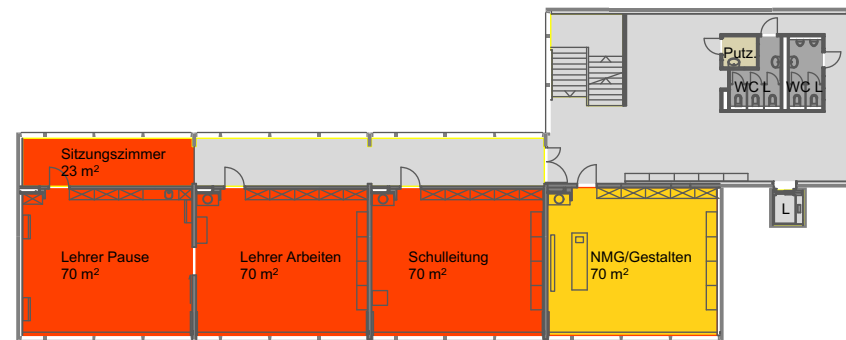

1. Untergeschoss

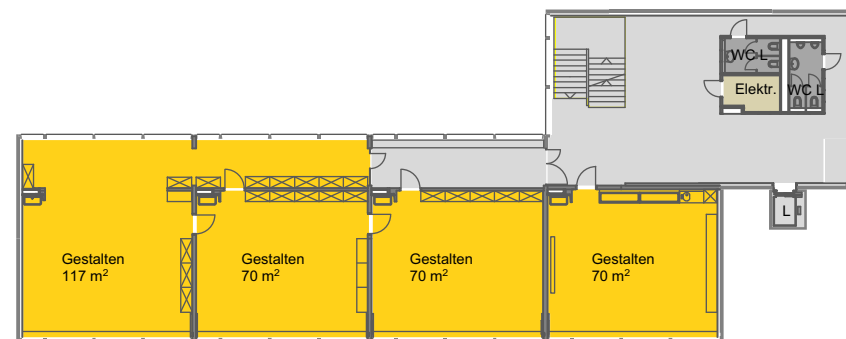

2. Untergeschoss

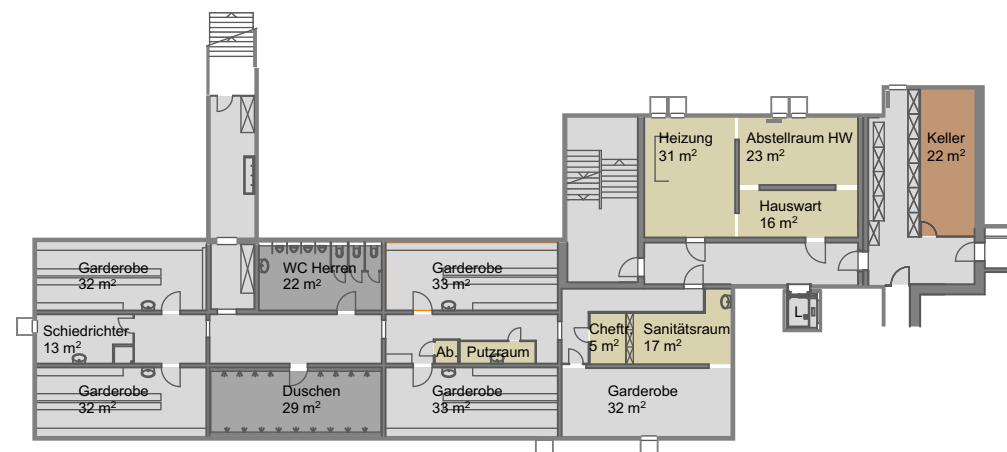

4. Obergeschoss

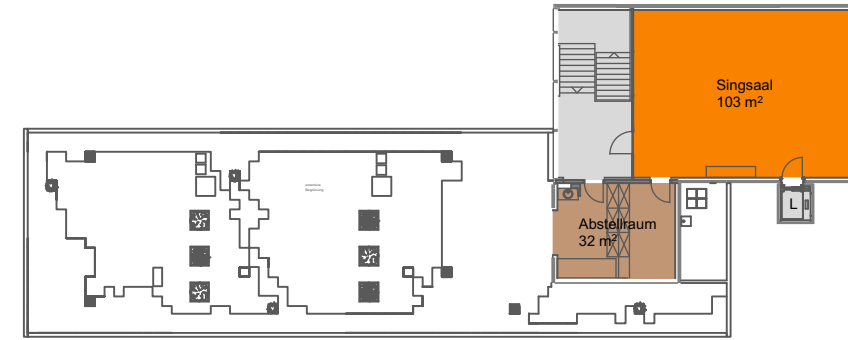

3. Obergeschoss

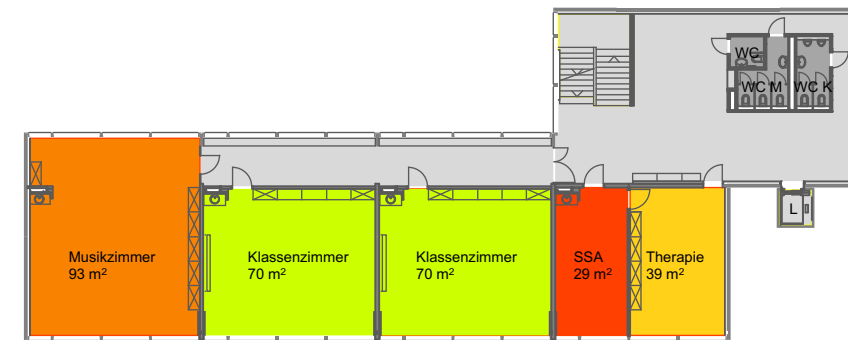

2. Obergeschoss

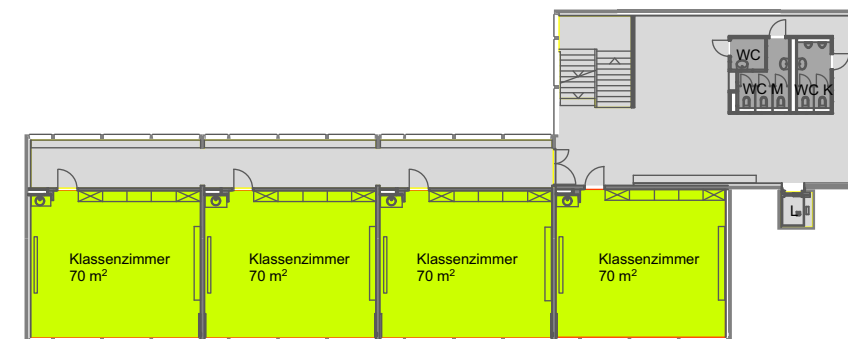

Gemeinde Ostermundigen

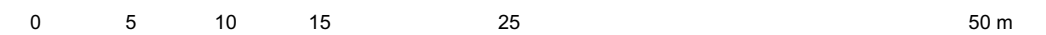

Schulraumplanung

Schulanlage Rüti; Bestand

Grundrisse Klassentrakt 1

1:400

Plan-Nr.	0.4.1	Dateiname	SH_Rüti
Grösse	A3	Status	Entwurf
Erstellung	10.12.2018		
Revision	25.01.2019		
Projektverfasserin	IC Infraconsult AG		

1. Obergeschoss

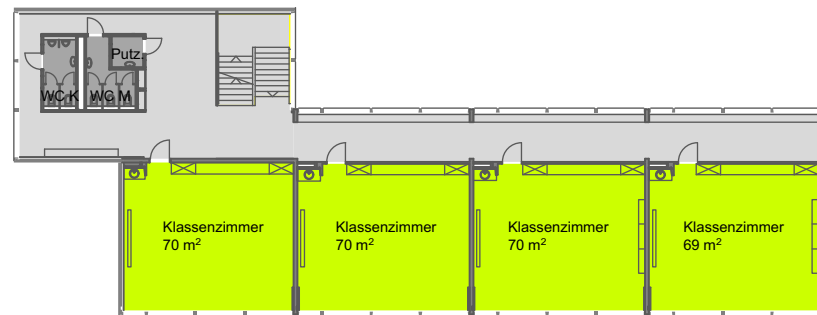

2. Obergeschoss

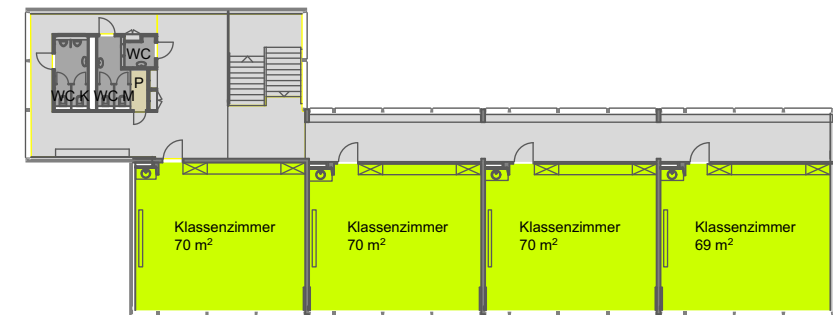

Erdgeschoss

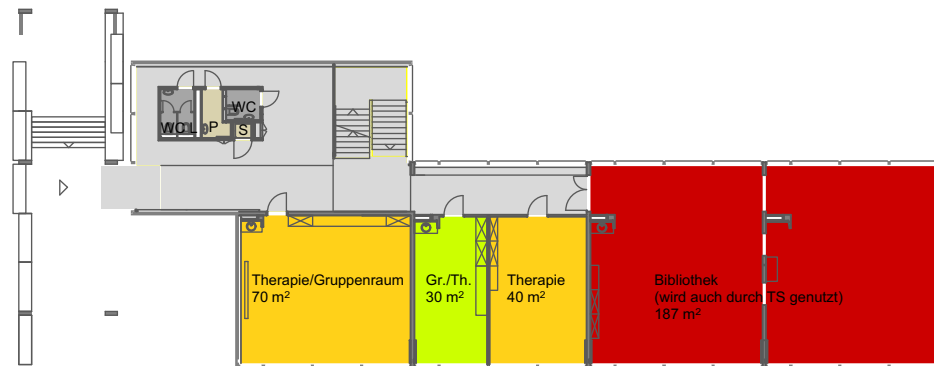

Rüti Wohnhaus

Untergeschoss

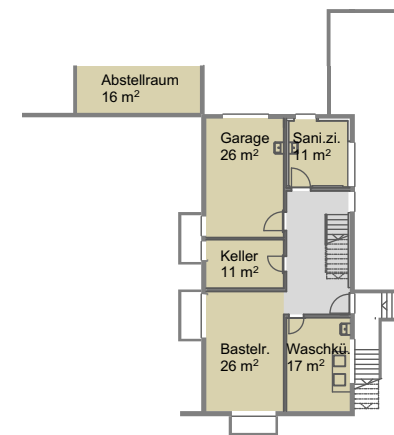

Erdgeschoss

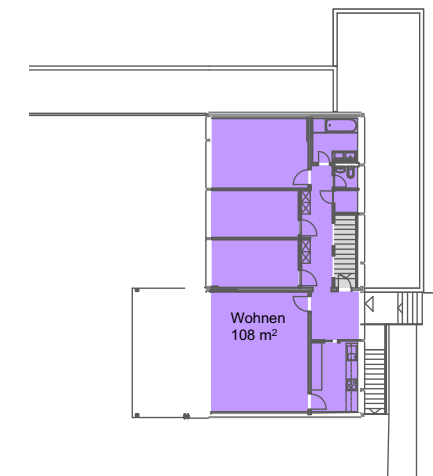

Untergeschoss

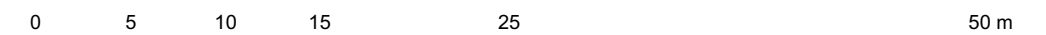
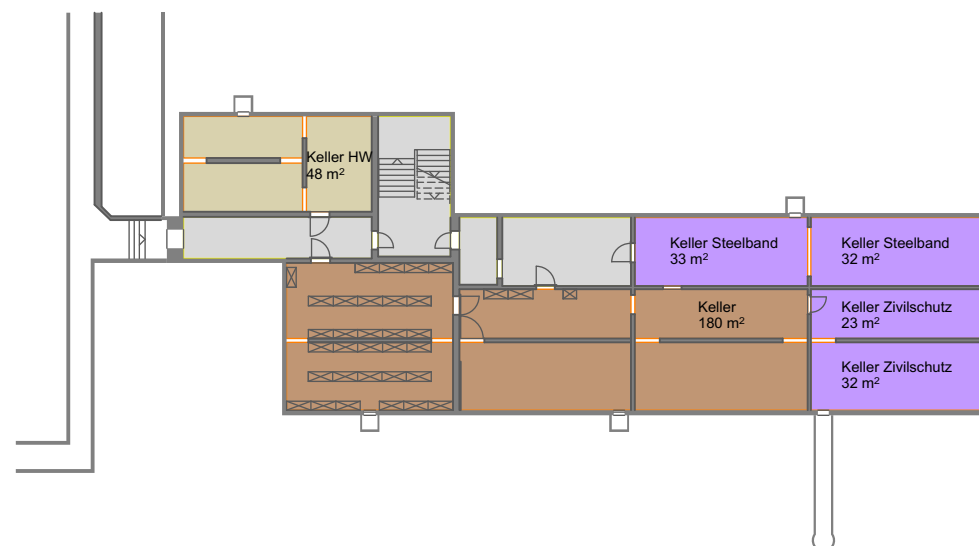

Schulraumplanung

Schulanlage Rüti; Bestand

Grundrisse Klassentrakt 2 und Wohnhaus

1:400

Plan-Nr.	0.4.2	Dateiname	SH_Rüti
Grösse	A3	Status	Entwurf
Erstellung	10.12.2018		
Revision	25.01.2019		
Projektverfasserin	IC Infraconsult AG		

2. Untergeschoss

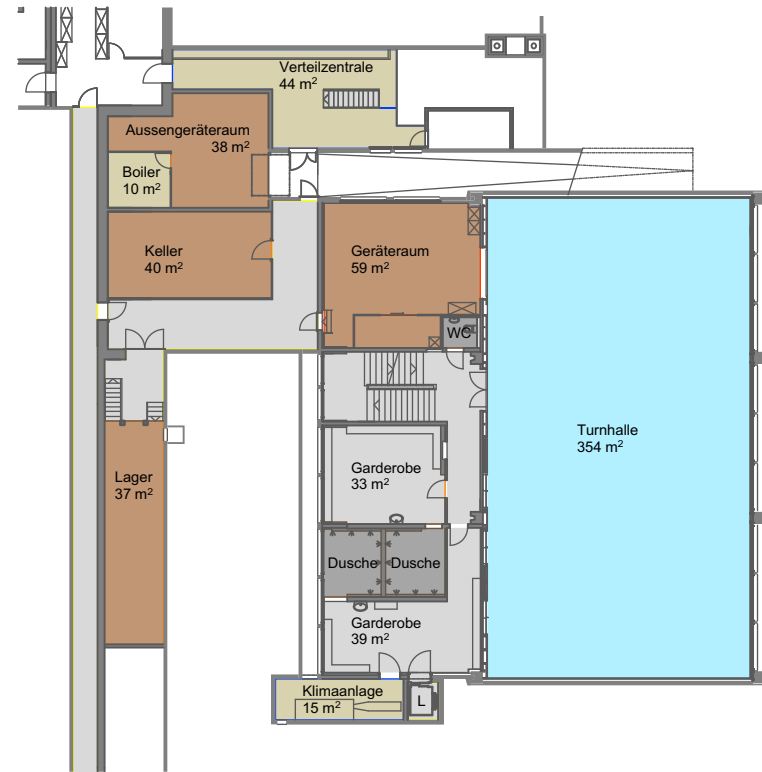

1. Untergeschoss

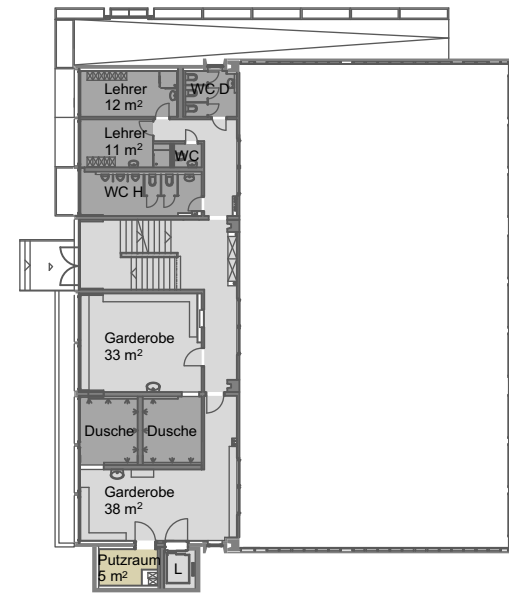

Erdgeschoss

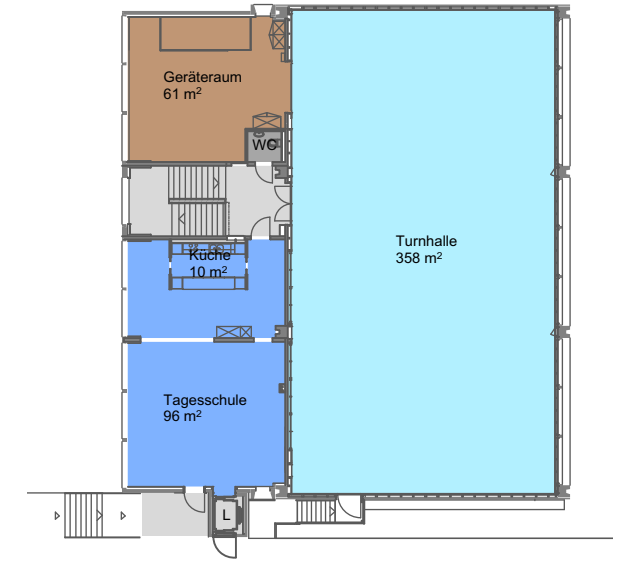

Gemeinde Ostermundigen

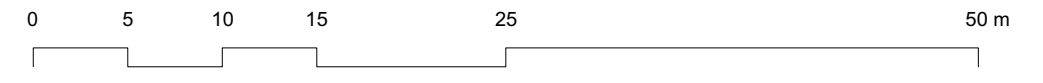

Schulraumplanung

Schulanlage Rüti; Bestand

Grundrisse Turnhalle

1:400

Plan-Nr.	0.4.3	Dateiname	SH_Rüti
Grösse	A3	Status	Entwurf
Erstellung	10.12.2018		
Revision	25.01.2019		
Projektverfasserin	IC Infraconsult AG		

Rothus Hauptgebäude (Nutzung durch Christophorus Schule Bern)

2. Obergeschoss (Nutzung durch Schule Mösli)

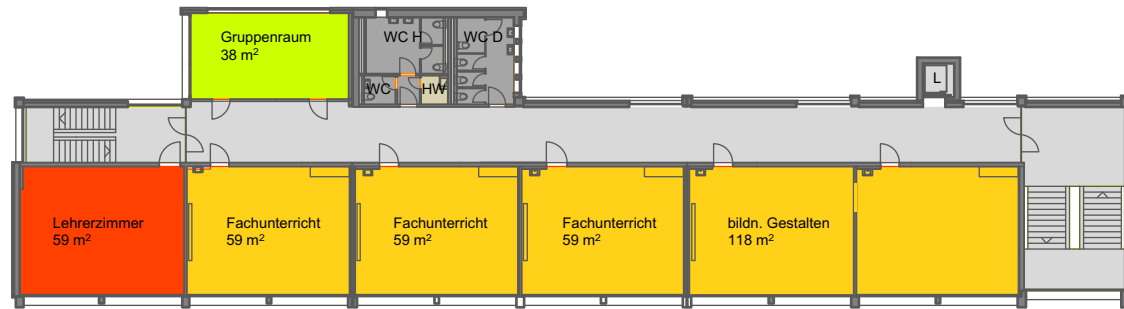

1. Obergeschoss

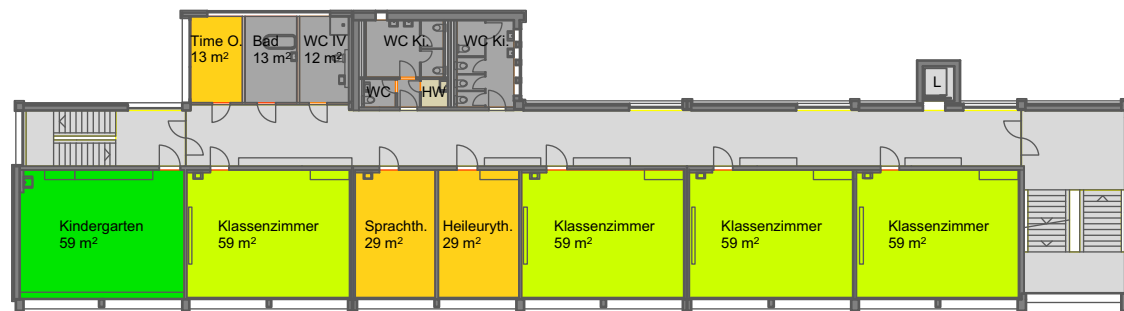

Erdgeschoss

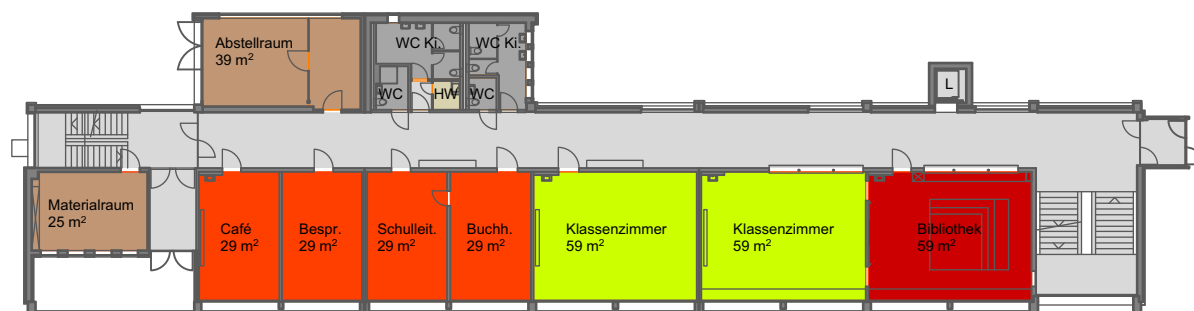

Untergeschoss

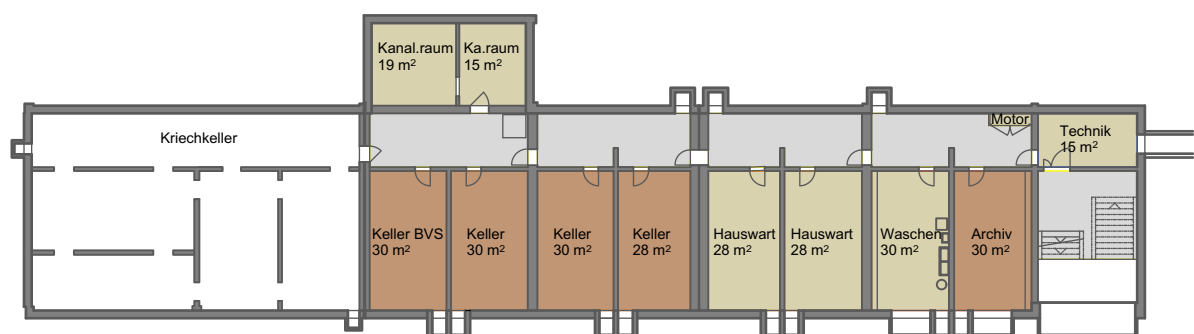

Rothus Spezialgebäude (Nutzung durch Christophorus Schule Bern)

Obergeschoss

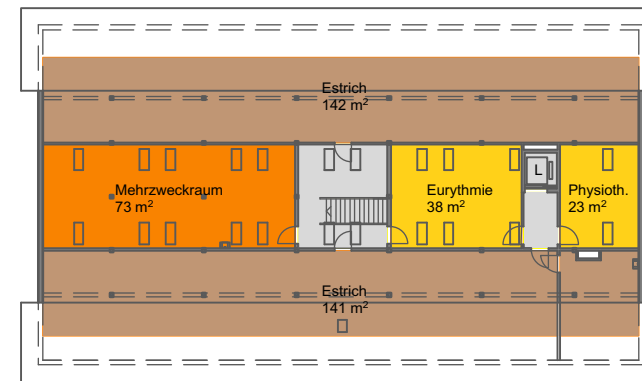

Erdgeschoss

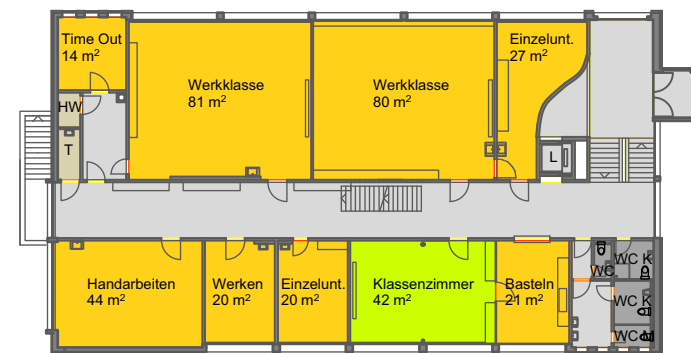

Untergeschoss

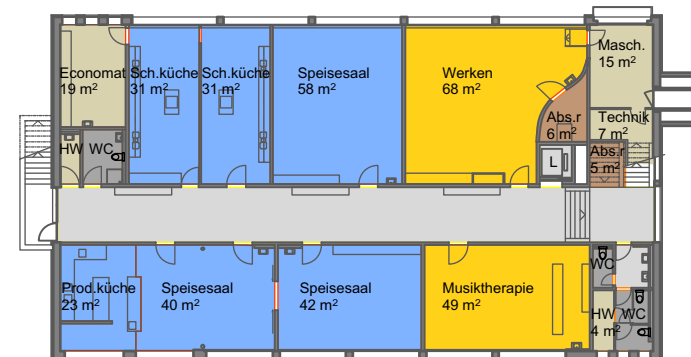

Gemeinde Ostermundigen

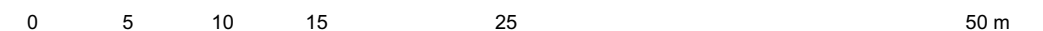

Schulraumplanung

Schulanlage Rothus; Bestand

Grundrisse Hauptgebäude/Spezialtrakt

1:400

Plan-Nr.	0.5.1	Dateiname	SH_Rothus
Grösse	A3	Status	Entwurf
Erstellung	10.12.2018		
Revision	25.01.2019		
Projektverfasserin	IC Infraconsult AG		

Obergeschoss

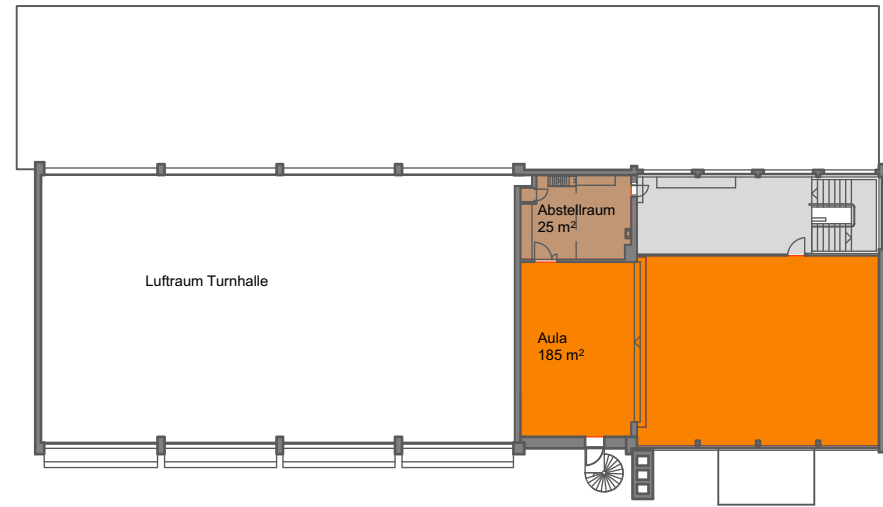

Erdgeschoss

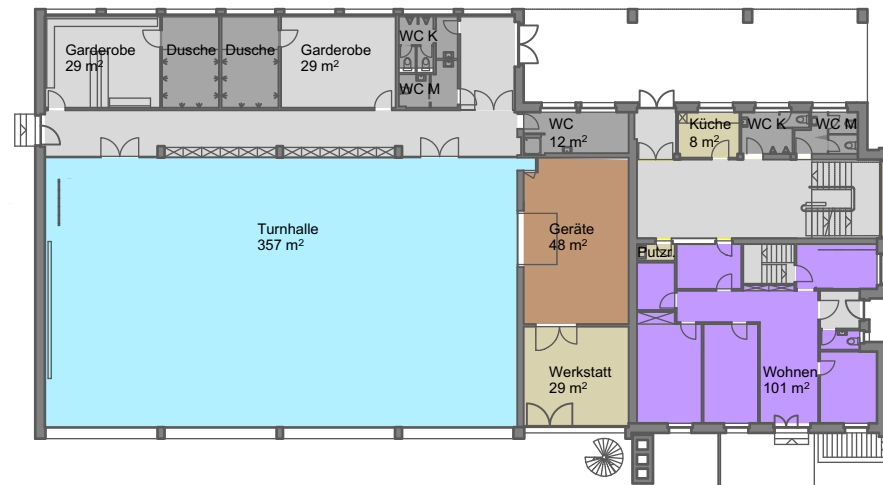

Untergeschoss

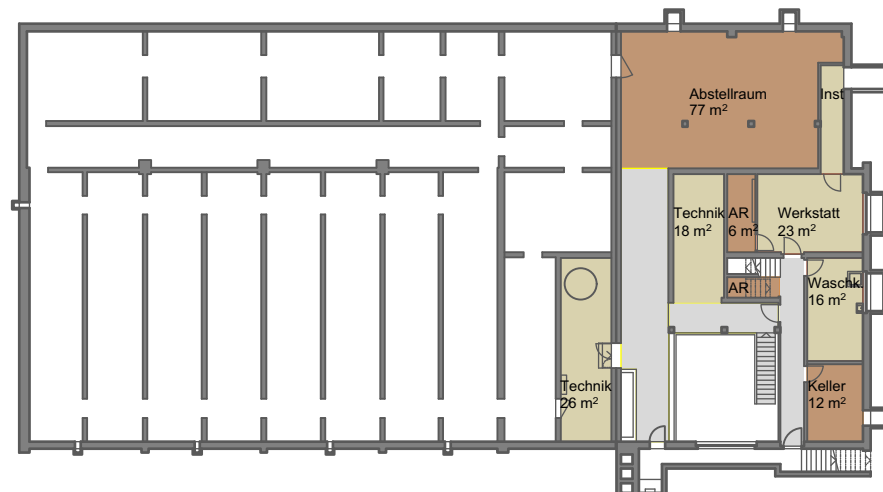

Gemeinde Ostermundigen



Schulraumplanung

Schulanlage Rothus; Bestand

Grundrisse Turnhalle

1:400

Plan-Nr.	0.5.2	Dateiname	SH_Rothus
Grösse	A3	Status	Entwurf
Erstellung	10.12.2018		
Revision	25.01.2019		
Projektverfasserin	IC Infraconsult AG		